

## The Structure of 1,3-*trans*-Bis(4-chlorophenyl)-2,4-*trans*-di(4-pyridyl)cyclobutane, a Photodimer of 4'-Chloro-4-styrylpyridine

BY V. BUSETTI, G. VALLE, G. ZANOTTI AND G. GALIAZZO

*Istituto di Chimica Organica, Università di Padova, and Biopolymer Research Center, CNR, Via Marzolo 1, 35100 Padova, Italy*

(Received 21 March 1979; accepted 2 January 1980)

### Abstract

The crystal structure of 1,3-*trans*-bis(4-chlorophenyl)-2,4-*trans*-di(4-pyridyl)cyclobutane, C<sub>26</sub>H<sub>20</sub>Cl<sub>2</sub>N<sub>2</sub>, has been determined from 1765 three-dimensional intensities, collected with an automated Philips PW 1100 four-circle single-crystal diffractometer and refined to  $R = 0.058$ . Cell constants are  $a = 16.307$  (8),  $b = 13.907$  (2),  $c = 9.666$  (3) Å,  $\beta = 94.47$  (5)°,  $Z = 4$ ; the space group is  $P2_1/n$ . The cyclobutane ring has a puckered conformation, and the two dihedral angles are 19.1 and 19.2°. The structure determined shows that the dimerization process is a head-to-tail reaction.

### Introduction

One of us (GG) prepared the title compound by the irradiation for 44 h of *trans*-4'-chloro-4-styrylpyridine in benzene solution at room temperature with a Hanovia 1000 W high-pressure quartz lamp. It was purified by chromatography in Al<sub>2</sub>O<sub>3</sub> columns (benzene eluent) and characterized by UV spectra ( $\lambda_{\text{max}} = 248$  nm). The method applied was largely that reported by Williams, Webster & Van Allan (1961) for *trans*-2-styrylpyridine hydrochloride. The structure determination was undertaken to elucidate the stereochemistry of the product.

### Experimental

Crystals were grown by slow evaporation from petroleum ether/benzene (1:1) solutions. Data were collected on a Philips PW 1100 four-circle single-crystal diffractometer. Cell parameters were obtained by least-squares refinement of 32 high-order reflection angles.

In the  $\theta$ - $2\theta$  scan mode, with Mo  $K\alpha$  radiation monochromatized by graphite, 3471 independent reflections, of which 1765 had  $I > 2\sigma(I)$ , were collected up to  $2\theta = 46^\circ$ . Usual Lorentz and polarization factors were applied, but none were necessary for absorption

since the minimum and the maximum transmission factors were 0.87 and 0.93 respectively.

Scattering factors for Cl, N, O and C were taken from Cromer & Mann (1968), and those for H were taken from Stewart, Davidson & Simpson (1965). Calculations were performed on the Cyber 76 computer using the XRAY 70 system of crystallographic programs (Stewart, Kundell & Baldwin, 1970).

### Structure determination and refinement

Data were phased by the *MULTAN* program of Germain, Main & Woolfson (1971). In the *E* map generated from this set of phases the 36 highest peaks were retained; the two highest ones, with the same weight, were interpreted as Cl atoms and all other peaks as C atoms. At this stage the *R* value was 44% with an overall temperature factor  $B = 3.2$  Å<sup>2</sup>. Six peaks were withdrawn, because they were not consistent with the chemical formula. Of four peaks, two nearly coincident pairs, the two which better fitted the geometrical model were retained. Coordinates of two missing peaks, C(21) and C(22), were calculated.

After these adjustments the *R* factor dropped to 31%. Two cycles of diagonal least-squares refinement, with individual isotropic thermal factors and unit weights, improved the *R* index to 17%. The refinement was then continued by full-matrix least squares; atoms were divided into two blocks and only Cl atoms were refined anisotropically. The weighting scheme was  $w =$

Table 1. *Crystal data*

C <sub>26</sub> H <sub>20</sub> Cl <sub>2</sub> N <sub>2</sub>	$M_r = 431.34$
Monoclinic	$D_c = 1.31$ Mg m <sup>-3</sup>
Space group $P2_1/n$	$D_m = 1.30$ (by flotation in KI solution)
$a = 16.307$ (8) Å	$\mu(\text{Mo } K\alpha) = 0.32$ mm <sup>-1</sup>
$b = 13.907$ (2)	m.p. 472–476 K
$c = 9.666$ (3)	Crystal size 0.2 × 0.4 × 0.2 mm
$\beta = 94.47$ (5)°	Systematic absences:
$V = 2185.40$ Å <sup>3</sup>	$h0l: h + l = 2n + 1$
$Z = 4$	$0k0: k = 2n + 1$
$F(000) = 896$	

Table 2. Fractional atomic coordinates for non-hydrogen ( $\times 10^4$ ) and hydrogen ( $\times 10^3$ ) atoms

Least-squares e.s.d.'s are in parentheses. The H atoms are given the numbers of the C atoms to which they are bonded.

	x	y	z		x	y	z
Cl(1)	3915 (1)	4078 (1)	-877 (2)	C(22)	-715 (5)	1313 (6)	-1919 (8)
Cl(2)	-4157 (1)	3137 (2)	292 (2)	C(23)	685 (3)	2561 (5)	826 (7)
N(1)	948 (3)	5655 (4)	4119 (6)	C(24)	106 (3)	3176 (5)	1709 (7)
N(2)	-1368 (3)	-100 (4)	-1093 (6)	C(25)	-462 (3)	3360 (5)	393 (7)
C(1)	2977 (3)	3625 (5)	-414 (7)	C(26)	-13 (3)	2543 (5)	-383 (6)
C(2)	2298 (4)	4220 (4)	-569 (7)	H(2)	231 (5)	491 (7)	-101 (9)
C(3)	1550 (3)	3869 (5)	-147 (7)	H(3)	107 (5)	437 (6)	-30 (8)
C(4)	1484 (3)	2955 (5)	400 (6)	H(5)	212 (5)	162 (6)	88 (8)
C(5)	2191 (3)	2376 (4)	505 (6)	H(6)	345 (5)	235 (6)	28 (8)
C(6)	2925 (3)	2719 (5)	100 (7)	H(8)	-148 (5)	310 (6)	257 (8)
C(7)	-1385 (3)	3312 (5)	434 (8)	H(9)	-290 (4)	297 (6)	248 (8)
C(8)	-1777 (4)	3106 (6)	1629 (8)	H(11)	-299 (5)	344 (6)	-180 (8)
C(9)	-2619 (4)	3052 (6)	1584 (8)	H(12)	-162 (5)	365 (6)	-158 (9)
C(10)	-3089 (4)	3181 (6)	359 (9)	H(14)	151 (5)	353 (6)	322 (8)
C(11)	-2723 (4)	3402 (6)	-831 (8)	H(15)	205 (5)	487 (6)	456 (9)
C(12)	-1868 (4)	3450 (5)	-788 (8)	H(16)	-20 (5)	619 (6)	362 (9)
C(13)	430 (4)	4047 (5)	2522 (7)	H(17)	-68 (5)	481 (6)	229 (9)
C(14)	1211 (4)	4101 (6)	3209 (8)	H(19)	-48 (5)	108 (6)	148 (8)
C(15)	1426 (5)	4909 (7)	3995 (9)	H(20)	-120 (5)	-24 (6)	102 (9)
C(16)	203 (5)	5601 (6)	3490 (9)	H(21)	-138 (5)	22 (6)	-320 (8)
C(17)	-79 (4)	4828 (6)	2693 (8)	H(22)	-60 (5)	170 (6)	-275 (8)
C(18)	-476 (3)	1612 (5)	-592 (7)	H(23)	74 (5)	190 (6)	127 (8)
C(19)	-700 (4)	1036 (6)	484 (8)	H(24)	-16 (5)	267 (6)	245 (8)
C(20)	-1141 (4)	191 (6)	171 (8)	H(25)	-40 (5)	407 (6)	-6 (8)
C(21)	-1149 (5)	448 (7)	-2089 (9)	H(26)	17 (5)	270 (6)	-141 (8)

$\{1 + [(|F_o| - b)/a]^2\}^{-1}$ . The  $R$  factor converged to 10.9%.

In a final difference Fourier map, all positive electron density peaks of about  $0.6 \text{ e } \text{Å}^{-3}$  could be interpreted as H atoms; remaining values ranged from  $-0.2$  to  $0.2 \text{ e } \text{Å}^{-3}$ . Only H-atom coordinates with isotropic temperature factors were then refined by one cycle of full-matrix least squares with unit weights, including 1314 reflections up to  $2\theta = 40^\circ$ .

A final cycle of full-matrix least squares, with anisotropic thermal parameters for all atoms except H and unit weights, gave an  $R$  factor of 5.8%.

Crystal data are in Table 1. Final positional parameters are given in Table 2.\*

### Results and discussion

Bond lengths and the numbering scheme of the molecule are shown in Fig. 1(a), bond angles and deviations of atoms from their own ring planes are shown in Fig. 1(b). In Table 3 mean-plane equations with deviations of atoms not lying on them and interplane angles are summarized.

\* Lists of structure factors and thermal parameters have been deposited with the British Library Lending Division as Supplementary Publication No. SUP 34949 (17 pp.). Copies may be obtained through The Executive Secretary, International Union of Crystallography, 5 Abbey Square, Chester CH1 2HU, England.

The cyclobutane ring has a puckered conformation, the dihedral angle between the C(23)C(24)C(25) and C(25)C(26)C(23) planes is  $19.1^\circ$  and that between the C(24)C(25)C(26) and C(26)C(23)C(24) planes is  $19.2^\circ$ ; these values are similar to the lowest values cited by Cotton & Frenz (1974) in their review of compounds containing a cyclobutane ring.

Of the four independent C—C bonds, one [1.536 (7) Å], is significantly shorter (5 $\sigma$ ) than the other three [1.573 (7), 1.574 (7) and 1.567 (7) Å], which are rather long for a normal C—C single bond. In Cotton's review there were also examples of unequal bonds: 1.525 (5) and 1.550 (5) Å in cyclobutyl chloride (Hyunyon & Gwinn, 1966); 1.526 (3) and 1.556 (4) Å in *cis*-1,2-cyclobutanedicarboxylic acid (van der Helm, Hsu & Sims, 1972); 1.466 (7), 1.486 (7) and 1.494 (5) Å in perchloro[4]radialene (Van Remoortere & Boer, 1970); and 1.553 (6) and 1.517 (6) Å in *trans*-1,2-cyclobutanedicarboxylic acid (Benedetti, Corradini & Pedone, 1970). More recently, values even larger than ours have been reported: 1.591 (7) Å in 2-(2,6-dimethylphenylimino)-3,3-dimethyl-4,4-diphenylthietane (Bertolasi & Gilli, 1978); 1.614 (3) Å in (*E*)-3-benzylidene-1-*tert*-butyl-2-oxo-4-*trans*-phenylcyclobutanecarbonitrile (McDonald, 1975); and 1.606 (6) Å in a dimer from 1-phenyl-3,3-biphenyleneallene (Dreissig, Luger & Rewicki, 1974).

The four C—C bonds merging from C(23), C(24), C(25) and C(26) are bent with respect to the plane through each of these atoms and the two adjacent ones

Table 3. *Least-squares-planes equations,  $m_1x + m_2y + m_3z = d$ , referred to a, b, c\* axes, and deviations,  $\Delta d$  (Å), of atoms (not in the planes) less than 0.5 Å (e.s.d.'s range from 0.005 to 0.015 Å)*

	A	B	C	D	E	F	G	H	I
1	Cl(1)	Cl(1)	C(7)	C(14)	H(5)	C(26)	C(26)	C(13)	C(7)
2	C(8)	Cl(2)	C(11)	C(15)	H(12)	H(5)	H(12)	C(24)	C(12)
3	C(9)	C(1)	C(18)	C(24)		H(12)	H(17)	H(5)	C(25)
4	C(23)	C(3)	C(24)	C(26)		H(26)	H(23)	H(12)	H(5)
5	C(25)	C(24)	H(14)	H(3)				H(14)	H(11)
6	H(2)	C(25)	H(15)	H(19)				H(17)	H(22)
7	H(3)	H(8)	H(16)	H(20)				H(22)	
8	H(5)	H(9)	H(17)	H(21)					
9	H(6)	H(11)	H(23)	H(22)					
10	H(19)	H(12)		H(26)					
11	H(23)								
12	H(25)								
$m_1$	0.1571	-0.0651	-0.4070	0.8624	0.5410	0.5389	0.6756	0.5297	0.3995
$m_2$	0.3559	0.9772	-0.4268	-0.5056	0.7668	0.8216	0.6711	0.6917	0.8390
$m_3$	0.9212	0.2019	0.8076	-0.0234	-0.3455	-0.1857	-0.3052	-0.4909	-0.3735
$d$	2.1852	4.7351	-0.6405	-1.7545	2.9350	3.3469	2.4911	2.6315	3.1082
$\Delta d, 1$	0.068	0.217	0.055	0.293	0.334	-0.369	0.367	0.339	-0.306
$\Delta d, 2$	0.324	0.028	-0.244	-0.041	0.120	0.174	-0.322	-0.361	0.020
$\Delta d, 3$	0.042	-0.207	-0.479	-0.479		-0.251	0.461	0.306	0.361
$\Delta d, 4$	-0.019	0.329	0.067	-0.018		0.196	-0.336	0.292	-0.193
$\Delta d, 5$	-0.296	-0.089	0.146	0.218				0.418	-0.325
$\Delta d, 6$	-0.050	-0.041	0.077	0.194				0.235	0.439
$\Delta d, 7$	-0.015	0.146	0.022	0.152				0.104	
$\Delta d, 8$	-0.067	0.104	0.090	-0.060					
$\Delta d, 9$	0.107	-0.104	0.046	-0.048					
$\Delta d, 10$	-0.482	0.082		0.226					
$\Delta d, 11$	0.058								
$\Delta d, 12$	-0.326								
$A \wedge B$	58.4°	$B \wedge C$ 76.8°	$C \wedge D$ 81.1°	$D \wedge E$ 85.0°	$E \wedge F$ 9.7°	$F \wedge G$ 13.5°	$G \wedge H$ 13.6°	$H \wedge I$ 13.3°	
$A \wedge C$	58.1	$B \wedge D$ 56.3	$C \wedge E$ 34.3	$D \wedge F$ 86.9	$E \wedge G$ 9.8	$F \wedge H$ 19.1	$G \wedge I$ 19.2		
$A \wedge D$	86.2	$B \wedge E$ 49.9	$C \wedge F$ 43.9	$D \wedge G$ 75.5	$E \wedge H$ 9.4	$F \wedge I$ 13.6			
$A \wedge E$	87.7	$B \wedge F$ 43.1	$C \wedge G$ 36.1	$D \wedge H$ 83.2	$E \wedge I$ 9.5				
$A \wedge F$	78.1	$B \wedge G$ 56.6	$C \wedge H$ 24.9	$D \wedge I$ 85.7					
$A \wedge G$	86.3	$B \wedge H$ 57.2	$C \wedge I$ 34.8						
$A \wedge H$	82.9	$B \wedge I$ 44.0							
$A \wedge I$	89.0								

Plane *A* is through atoms C(1)C(2)C(3)C(4)C(5)C(6), plane *B* through C(7)C(8)C(9)C(10)C(11)C(12), plane *C* through C(13)C(14)C(15)N(1)C(16)C(17), plane *D* through C(18)C(19)C(20)N(2)C(21)C(22), plane *E* through C(23)C(24)C(25)C(26), plane *F* through C(23)C(24)C(25), plane *G* through C(24)C(25)C(26), plane *H* through C(25)C(26)C(23) and plane *I* through C(26)C(23)C(24).

in the cyclobutane ring by 49.5, 46.6, 45.4 and 52.2° respectively; however, they are nearly coplanar with the six-membered-ring planes, the bending angles to the *A*, *C*, *B* and *D* planes being 1.0, 2.8, 1.6 and 0.8° respectively (see also Table 3).

The cyclobutane ring with surrounding atoms is more clearly shown in Fig. 2; the two torsion angles C(4)–C(23)–C(24)–C(13) and C(7)–C(25)–C(26)–C(18) are -18.6 and +20.7° respectively. The four attached six-membered rings, going from C(23) to C(26), are in the *cis-trans-cis-trans* configuration with respect to the cyclobutane plane; so it can be deduced that the dimerization process is in any case a head-to-tail reaction, whether the *trans* configuration of the monomer is retained in solution or whether there is a *trans*  $\rightleftharpoons$  *cis* isomerization.

The two bond lengths Cl(1)–C(1) and Cl(2)–C(10), 1.745 (5) Å and 1.739 (5) Å, are in good agreement with the mean value reported in the literature [1.740 (1) Å in Domenicano, Vaciago & Coulson (1975)]; the two bonds are bent by 1.9 and 1.3° respectively to their benzene planes. The endocyclic angles [121.5 (3)° at C(1) and 120.2 (3)° at C(10)] compare well with values reported in the above-mentioned literature.

The two pyridine rings have expected values for angles and lengths.

Concerning intramolecular contacts, there is a distance Cl(1)⋯C(2)(1 + *x*, *y*, *z*) of 3.510 (3) Å which is similar to the sum of the van der Waals radii [3.45 Å (Bondi, 1964) and the lower value of 3.3 Å cited by some authors (Van Remoortere & Boer, 1970, and references therein)]. The H(2) atom points towards

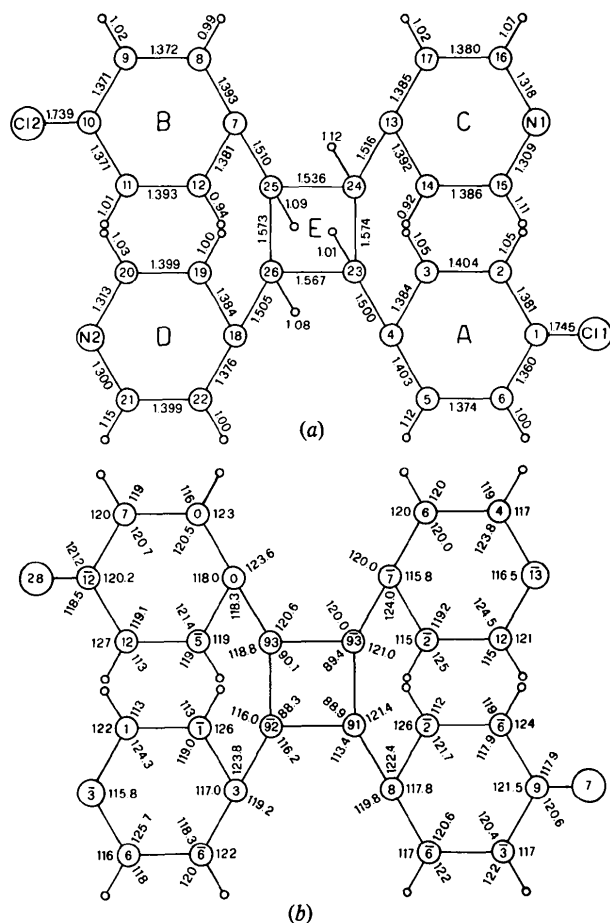

Fig. 1. (a) Bond lengths (Å) and numbering of atoms. Mean e.s.d.'s are:  $\sigma_{\text{Cl}-\text{C}} = 0.005$ ,  $\sigma_{\text{C}-\text{N}} = 0.007$ ,  $\sigma_{\text{C}-\text{C}} = 0.007$  and  $\sigma_{\text{C}-\text{H}} = 0.06$  Å. (b) Deviations of atoms from their ring planes ( $\times 10^3$  Å) (mean e.s.d. 0.004 Å) and bond angles ( $^\circ$ ). Mean e.s.d.'s are:  $\sigma_{\text{Cl}-\text{C}-\text{C}} = 0.3$ ,  $\sigma_{\text{C}-\text{C}-\text{C}} = 0.4$ ,  $\sigma_{\text{C}-\text{N}-\text{C}} = 0.4$  and  $\sigma_{\text{H}} = 2.0^\circ$ .

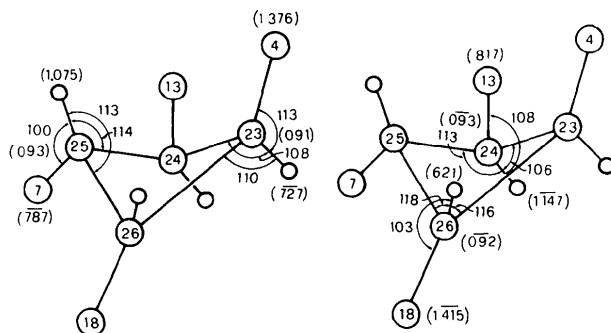

Fig. 2. The cyclobutane ring with the surrounding atoms. Distances (Å) from the mean cyclobutane ring are given in parentheses (mean e.s.d. 0.005 Å).

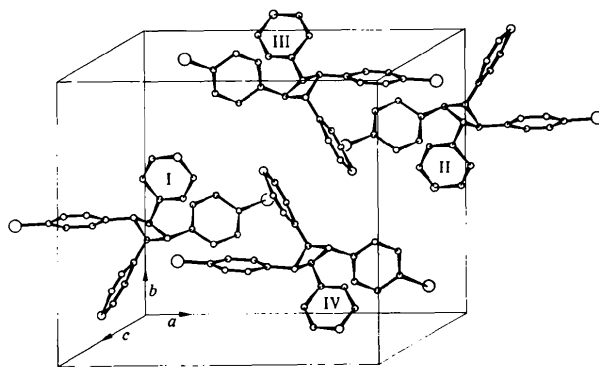

Fig. 3. A perspective drawing of the contents of one unit cell.

phenyl ring *B* of the molecule at  $\bar{x}$ ,  $1 - y$ ,  $\bar{z}$ , equidistant from all six atoms of the ring with a mean value of 2.97 Å, near to the sum of the covalent radii (2.90 Å, Bondi, 1964); H(3) is 2.28 Å from H(17) of the same molecule; H(11) is a short distance from C(5) and H(5) at  $-\frac{1}{2} + x$ ,  $\frac{1}{2} - y$ ,  $-\frac{1}{2} + z$  (2.26 and 2.88 Å respectively).

The contents of the unit cell are shown in Fig. 3.

### References

- BENEDETTI, E., CORRADINI, P. & PEDONE, C. (1970). *Acta Cryst.* B26, 493–498.
- BERTOLASI, V. & GILLI, G. (1978). *Acta Cryst.* B34, 3403–3407.
- BONDI, A. (1964). *J. Phys. Chem.* 68, 441–451.
- COTTON, F. A. & FRENZ, B. A. (1974). *Tetrahedron*, 30, 1587–1594.
- CROMER, D. T. & MANN, J. B. (1968). *Acta Cryst.* A24, 321–324.
- DOMENICANO, A., VACIAGO, A. & COULSON, C. A. (1975). *Acta Cryst.* B31, 1630–1641.
- DREISSIG, W., LUGER, P. & REWICKI, D. (1974). *Acta Cryst.* B30, 2037–2042.
- GERMAIN, G., MAIN, P. & WOOLFSON, M. M. (1971). *Acta Cryst.* A27, 368–376.
- HYUNYONG, K. & GWINN, D. W. (1966). *J. Chem. Phys.* 44, 865–873.
- MCDONALD, W. S. (1975). *Acta Cryst.* B31, 2504–2505.
- STEWART, J. M., KUNDELL, F. A. & BALDWIN, J. C. (1970). The XRAY 70 system. Computer Science Center, Univ. of Maryland, College Park, Maryland.
- STEWART, R. F., DAVIDSON, E. R. & SIMPSON, W. T. (1965). *J. Chem. Phys.* 42, 3175–3187.
- VAN DER HELM, D., HSU, I-N. & SIMS, J. M. (1972). *Acta Cryst.* B28, 3109–3114.
- VAN REMOORTERE, F. P. & BOER, F. P. (1970). *J. Am. Chem. Soc.* 92, 3355–3360.
- WILLIAMS, J. L. R., WEBSTER, S. K. & VAN ALLAN, J. A. (1961). *J. Org. Chem.* 26, 4893–4895.